



ProLock™

GIRA. BLOQUEA. AJUSTA. SIEMPRE.



Catálogo de productos para los Estados Unidos

Marzo 2018

JG John Guest® | Montaje del futuro.

JGProLock.com





Montaje del futuro.

Bienvenidos a una nueva era de innovación en ingeniería. Presentamos JG ProLock™: una tecnología sin precedentes Twist-to-Lock con un “clic” audible y flechas de alineación visibles para indicar a los técnicos que la conexión está segura.

El compromiso con la ingeniería y la innovación ha hecho que John Guest se encuentre en marcas de clase mundial como BMW®, Porsche®, Whirlpool® y Delta® continuamente nos mantenga a la vanguardia.

Gira. Bloquea. Ajusta. Siempre.

Los conectores ProLock de John Guest tienen una pinza con dientes de acero inoxidable que agarra el tubo cuando se inserta completamente, y una junta tórica para proporcionar un sello a prueba de fugas. Al torcer en su lugar, la tapa de bloqueo, bloquea el tubo en su lugar, lo que garantiza la máxima seguridad. No se necesitan herramientas, soldadura, abrazaderas o pegamento.

VER VIDEO CÓMO HACER
UNA CONEXIÓN

JGProLock.com/How-To

Garantía

Como resultado de programas de pruebas a largo plazo y rigurosos estándares de calidad John Guest USA ofrece una garantía de 25 años por defectos en los materiales o en la manufactura de conexiones ProLock para plomería.

Los productos ProLock de John Guest son para sistemas normales de uso doméstico y proveídos de acuerdo con los términos y condiciones para la venta.



Normas y Afliciones

El producto ProLock cumple con las secciones aplicables de la última edición del Uniform Plumbing Code® y el International Plumbing Code®, incluyendo instalaciones detrás de la pared. Consulte los listados de código aplicables para la información más reciente. Los productos ProLock se fabrican en cumplimiento con las normas ASTM F877, CSA B137.5, y ASSE 1061.

ProLock también cumple con la Certificación de NSF 61 para componentes y materiales de sistema de agua potable incluido el Anexo G.

El sistema de alta calidad John Guest está certificada por BSI BS EN ISO 9001.

Beneficios

- Funciona con Cobre, PEX y CPVC
- Aprobado para instalaciones detrás de la pared
- Tecnología Twist-to-Lock
- Garantía de 25-Años
- Código-Aprobado

ProLock cumple con las pertinentes secciones de la última edición del código uniforme de plomería, y el código internacional de plomería incluyendo instalaciones detrás de la pared. Remitirse a los pertinentes códigos para la última información.



ProLock son fabricados de acuerdo con las normas de ASTM F877, CSA B137.5 y ASSE 1061.



Productos ProLock son certificados con el estándar NSF 61 para sistemas, componentes y materiales para agua de mesa y que estén en contacto con el agua de mesa incluido el Anexo G.



Los sistemas de alta calidad John Guest son certificados por BSI BS EN ISO 9001.

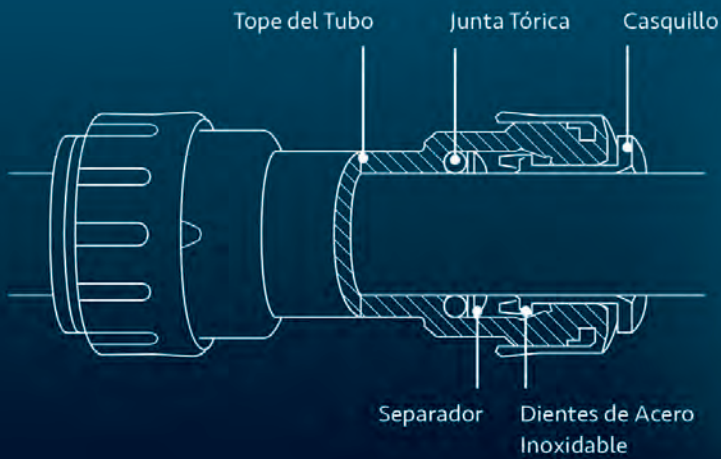

Para Conectar

1. Corte el tubo a escuadra, elimine todas las rebabas y bordes afilados.
2. Inserte el tubo por completo en el conector.
3. Gire la tapa un cuarto de vuelta en sentido horario a la posición cerrada. Se oirá un clic audible, marcas indicadoras estarán alineados.

MANTENGA EL PRODUCTO LIMPIO EN UNA BOLSA HASTA LISTO PARA USAR.

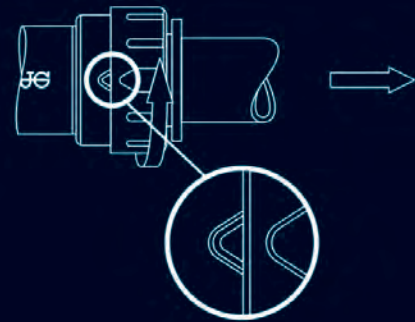
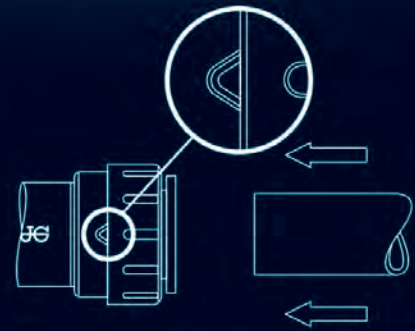

Para Desconectar

1. Descomprima el sistema.
2. Gire la tapa de cierre un cuarto de vuelta hacia la derecha.
3. Deprima el casquillo en contra de la instalación, retire el tubo.

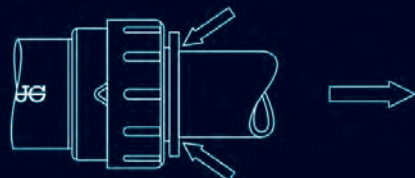

Conectores JG ProLock™

El rango de conectores ProLock Twist-to-Lock se ofrece en tamaños de 3/8" a 1" CTS. Han sido diseñados específicamente para el fontanero profesional y son fabricados con materiales plástico de alta calidad, y juntas tóricas de EPDM. El sistema ProLock Twist-to-Lock es adecuado para aplicaciones de cañerías de agua caliente y fría.



Para uso con Cobre, PEX y CPVC

TE

CODIGO	TAMAÑO CTS	CANT. BOLSA	CANT. CAJA
PSEI0216E	3/8"	5	50
PSEI0220E	1/2"	5	30
PSEI0228E	3/4"	5	15
PSEI0236E	1"	1	10



CODO

CODIGO	TAMAÑO CTS	CANT. BOLSA	CANT. CAJA
PSEI0316E	3/8"	10	80
PSEI0320E	1/2"	10	50
PSEI0328E	3/4"	5	30
PSEI0336E	1"	5	15



ACOPLE

CODIGO	TAMAÑO CTS	CANT. BOLSA	CANT. CAJA
PSEI0416E	3/8"	10	80
PSEI0420E	1/2"	10	50
PSEI0428E	3/4"	5	30
PSEI0436E	1"	5	20



ACOPLE DE REDUCCIÓN

CODIGO	TAMAÑO CTS	CANT. BOLSA	CANT. CAJA
PSEI202016E	1/2" X 3/8"	10	80
PSEI202820E	3/4" X 1/2"	5	40
PSEI203628E	1" X 3/4"	5	20



CODO DE REDUCCIÓN

CODIGO	TAMAÑO CTS	CANT. BOLSA	CANT. CAJA
PSEI212016E	1/2" X 3/8"	10	60
PSEI212820E	3/4" X 1/2"	5	40
PSEI213628E	1" X 3/4"	5	20



TE DE REDUCCIÓN

CODIGO	TAMAÑO CTS X CTS X CTS	CANT. BOLSA	CANT. CAJA
PSEI3016AE	1/2" X 1/2" X 3/8"	5	40
PSEI3028AE	3/4" X 3/4" X 1/2"	5	20
PSEI3028BE	3/4" X 1/2" X 1/2"	5	20
PSEI3028CE	1/2" X 1/2" X 3/4"	5	20
PSEI3028DE	3/4" X 1/2" X 3/4"	5	20
PSEI3036AE	1" X 1" X 3/4"	1	10



CODO ESPIGA

CODIGO	TAMAÑO ESPIGA X CTS	CANT. BOLSA	CANT. CAJA
PSEI222020E	1/2" X 1/2"	10	80
PSEI222828E	3/4" X 3/4"	5	40
PSEI223636E	1" X 1"	5	20



REDUCTOR

CODIGO	TAMAÑO ESPIGA X CTS	CANT. BOLSA	CANT. CAJA
PSEI062016E	1/2" X 3/8"	10	100
PSEI062820E	3/4" X 1/2"	10	80
PSEI063628E	1" X 3/4"	5	40



CONECTOR MACHO ROSCA NPT

CODIGO	TAMAÑO CTS X NPT	CANT. BOLSA	CANT. CAJA
PSEI011624E	3/8" X 1/2"	10	100
PSEI012024E	1/2" X 1/2"	10	80
PSEI012026E	1/2" X 3/4"	5	60
PSEI012824E	3/4" X 1/2"	5	50
PSEI012826E	3/4" X 3/4"	5	50
PSEI012828E	3/4" X 1"	5	30
PSEI013626E	1" X 3/4"	2	30
PSEI013628E	1" X 1"	2	20



VÁSTAGO ADAPTADOR MACHO ROSCA NPT

CODIGO	TAMAÑO ESPIGA X NPT	CANT. BOLSA	CANT. CAJA
PSEI052826E	3/4" X 3/4"	10	60
PSEI053628E	1" X 1"	10	40



CODO MACHO FIJO ROSCA NPT

CODIGO	TAMAÑO CTS X NPT	CANT. BOLSA	CANT. CAJA
PSEI482024E	1/2" X 1/2"	5	60



CONECTOR HEMBRA ROSCA NPS

CODIGO	TAMAÑO CTS X NPS	CANT. BOLSA	CANT. CAJA
PSEI622036E-L	1/2" X 3/4"	2	150
PSEI622836E-L	3/4" X 3/4"	2	150
PSEI622838E-L	3/4" X 1"	2	150
PSEI623638E-L	1" X 1"	2	100
PSEI62363AE-L	1" X 1 1/4"	1	75



CONECTOR CODO HEMBRA ROSCA NPS

CODIGO	TAMAÑO CTS X NPS	CANT. BOLSA	CANT. CAJA
PSEI632836E-L	3/4" X 3/4"	2	150
PSEI632838E-L	3/4" X 1"	2	100
PSEI63283AE-L	3/4" X 1 1/4"	1	75
PSEI63363AE-L	1" X 1 1/4"	1	75



VÁSTAGO ADAPTADOR HEMBRA ROSCA NPS

CODIGO	TAMAÑO ESPIGA X NPS	CANT. BOLSA	CANT. CAJA
PSEI502034E	1/2" X 1/2"	10	100



TAPÓN

CODIGO	TAMAÑO CTS	CANT. BOLSA	CANT. CAJA
PSEI4616E	3/8"	10	200
PSEI4620E	1/2"	10	150
PSEI4628E	3/4"	5	80
PSEI4636E	1"	5	40



UNIÓN PASANTE

CODIGO	TAMAÑO CTS	CANT. BOLSA	CANT. CAJA
1/2SCEP	1/2"	1	125
3/4SCEP	3/4"	1	75



TE ACUMULABLE

CODIGO	TAMAÑO CTS	CANT. BOLSA	CANT. CAJA
PSEI532020E	1/2" X 1/2" X 1/2"	5	40
PSEI532820E	3/4" X 3/4" X 1/2"	5	25
PSEI532828E	3/4" X 3/4" X 3/4"	5	20
PSEI533628E	1" X 1" X 3/4"	1	10



VÁLVULA DE CIERRE

CODIGO	TAMAÑO CTS	CANT. BOLSA	CANT. CAJA
PSEISV20EP	1/2"	1	100
PSEISV28EP	3/4"	1	75



CODO GIRATORIO HEMBRA

CODIGO	TAMAÑO D.E. X NH	CANT. BOLSA	CANT. CAJA
NC2723	3/8" X 3/4"-11.5	5	70



Conectores De Latón

CONECTOR MACHO ROSCA NPT

CODIGO	TAMAÑO CTS X NPT	CANT. BOLSA	CANT. CAJA
MWIO11624LF-E	3/8" X 1/2"	10	100
MWIO12024LF-E	1/2" X 1/2"	10	100
MWIO12026LF-E	1/2" X 3/4"	10	100
MWIO12824LF-E	3/4" X 1/2"	5	50
MWIO12826LF-E	3/4" X 3/4"	5	50
MWIO12828LF-E	3/4" X 1"	5	50
MWIO13626LF-E	1" X 3/4"	1	25
MWIO13628LF-E	1" X 1"	1	25



VÁSTAGO ADAPTADOR MACHO ROSCA NPT

CODIGO	TAMAÑO ESPIGA X NPT	CANT. BOLSA	CANT. CAJA
MWIO52024LF	1/2" X 1/2"	10	100
MWIO52826LF	3/4" X 3/4"	5	50



CONECTOR HEMBRA ROSCA NPS

CODIGO	TAMAÑO CTS X NPS	CANT. BOLSA	CANT. CAJA
PSEI601634E	3/8" X 1/2"	10	100
PSEI602034E	1/2" X 1/2"	10	80
PSEI602036E	1/2" X 3/4"	5	50
PSEI602834E	3/4" X 1/2"	5	30
PSEI602836E	3/4" X 3/4"	5	30
PSEI603638E	1" X 1"	5	25



CONECTOR CODO HEMBRA ROSCA NPS

CODIGO	TAMAÑO CTS X NPS	CANT. BOLSA	CANT. CAJA
PSEI612034E	1/2" X 1/2"	5	50
PSEI612836E	3/4" X 3/4"	5	30



CODO LATERAL HEMBRA EN LÁTON, ROSCA NPT

CODIGO	TAMAÑO CTS X NPT	CANT. BOLSA	CANT. CAJA
WBI2024E	1/2" X 1/2"	1	20



NO PARA APLICACIONES DE AGUA POTABLE

Mangueras

MANGUERAS - 18" LONGITUD

CODIGO	TAMAÑO	CANT. BOLSA	CANT. CAJA
PSFC20N3618E	1/2" CTS X 3/4" NPS	1	40
PSFC28N3618E	3/4" CTS X 3/4" NPS	1	40
PSFC28C2818E	3/4" CTS X 3/4" CTS	1	40



Exhibidores Para Punto De Venta

EXHIBIDOR PROLOCK

CODIGO	TAMAÑO
JGSTAND-PROLOCK	6' X 3'

EXHIBIDOR PROLOCK INCLUYE:

CODIGO	DESCRIPCIÓN	CANT. CAJA
PSEI4620E	1/2" CTS TAPÓN, NEGRO	40
PSEI4628E	3/4" CTS TAPÓN, NEGRO	20
PSEI0220E	1/2" CTS TE, NEGRO	10
PSEI0228E	3/4" CTS TE, NEGRO	5
PSEI0320E	1/2" CTS CODO, NEGRO	40
PSEI0328E	3/4" CTS CODO, NEGRO	20
PSEI0420E	1/2" CTS ACOPLE NEGRO	40
PSEI0428E	3/4" CTS ACOPLE NEGRO	20
PSEISV20EP	1/2" CTS VÁLVULA DE CIERRE, NEGRO	3
PSEISV28EP	3/4" CTS VÁLVULA DE CIERRE, NEGRO	3

TAMBIEN INCLUYE:

- EXHIBIDOR
- LITERATURE Y SOSTENDOR DE LITERATURE



PAQUETE PARA EL CONTRATISTA PROLOCK

CODIGO	TAMAÑO
PSEI-CONPAK-1	9" X 11" X 10"

PAQUETE PARA EL CONTRATISTA PROLOCK INCLUYE:

CODIGO	DESCRIPCIÓN	CANT. BOLSA
PSEI4620E	1/2" CTS TAPÓN, NEGRO	10
PSEI4628E	3/4" CTS TAPÓN, NEGRO	5
PSEI0320E	1/2" CTS CODO, NEGRO	10
PSEI0328E	3/4" CTS CODO, NEGRO	5
PSEI0420E	1/2" CTS ACOPLE, NEGRO	10
PSEI0428E	3/4" CTS ACOPLE, NEGRO	5



Listado de Verificación Técnica

GAMA DE PRODUCTOS PROLOCK (PSEI, MWI)

Conexiones y tubos deben ser mantenidos limpios y sin daño alguno previo a su uso.

- **Tamaños:** 3/8" a 1" CTS.
- **Tubos:** Los productos ProLock se pueden utilizar con: PEX, Cobre y tuberías de CPVC de acuerdo a las normas ASTM.
- ProLock no se puede utilizar en tubos de acero inoxidable.
- **Estándards:** Los productos ProLock son diseñados y fabricados sobre un sistema plenamente integrado y evaluado por B.S.I. a BS EN ISO9001. Productos Prolock también están listados con NSF-61, IAPMO y ICC.
- **No usar con gas, combustibles o aire comprimido.**
- **Presiones y Temperaturas de Funcionamiento:**

Aplicación	Presión Máxima	Temperatura Máxima
Agua	160 psi	73° F
Agua	100 psi	180° F
Agua	80 psi	200° F

- **Presión-Estalle (conexiones):** Los productos Prolock usados con Cobre, CPVC o PEX tolerarán muy bien presiones excesivas, por encima del servicio normal.
- **Aislación:** De acuerdo a los requerimientos del código.
- **Mínimo radio de curvatura (PEX):**

Diámetro del Tubo	3/8" CTS	1/2" CTS	3/4" CTS	1" CTS
Radio Mínimo	3"	3.5"	4.5"	12"

- **Distancia entre grapas (en pulgadas):** Tubos montados en superficie.

Diámetro del Tubo	Espacio entre clips	
	Colocación Horizontal	Colocación Vertical
3/8" CTS	16"	20"
1/2" CTS	16"	20"
3/4" CTS	20"	30"
1" CTS	30"	36"

- **Expansión: (tubo PEX):** 1% en longitud entre 68°F y 180°F.
- **Índice de Flujo:** Comparable con los sistemas de metal.
- **Limpiadores, Inhibidores y descapantes:** Para consejos acerca del uso de aditivos tales como inhibidores de corrosión se debe consultar con el fabricante del producto aditivo.
- **Pinturas y Químicos:** Usar solo pintura a base de agua o petróleo.
- **NO PERMITA EL CONTACTO CON** pinturas a base de celulosa, solventes o decapantes, flujo de soldadora o descalantes a base de ácido u otros productos agresivos.
- **Flujo de soldadora:** Ningún flujo de ningún tipo debe entrar en contacto con los productos ProLock. Debe tomarse extremo cuidado para asegurar que ese contacto no suceda.
- **Cloro:** ProLock es apto para agua que contenga hasta 4 ppm de cloro.
- **Exposición a la luz:** Los productos ProLock cuando son utilizados en el interior del edificio no son afectados por la luz solar. Cuando estos productos son utilizados afuera deben ser protegidos de los rayos ultravioletas pintándolos o revistiéndolos.
- **Clips para tubos:** Los clips para tubos no deben ser colocados a una distancia menor a 2.5 pulgadas del final de la conexión. El tubo debe ser adecuadamente sostenido por clips al efecto para prevenir estrés excesivo (carga de lateral) en la conexión.
- **Caquillos de refuerzo: Plomería:** John Guest recomienda el uso de casquillos de refuerzo para las conexiones de tubos de PEX con productos ProLock en instalaciones de plomería residencial estándar (agua fría y caliente).
- **Caquillos de refuerzo: Calefacción:** John Guest requiere el uso de casquillos de refuerzo para las conexiones de tubos de PEX con productos ProLock en todas las instalaciones de Calefacción

- **Conexión a calderas:** Un tubo de cobre de 35 pulgadas de largo como mínimo debe ser instalado entre la caldera y el sistema ProLock.
- **Conexión a calentadores de agua caliente:** Un tubo de cobre de 18 pulgadas de largo como mínimo debe ser instalado entre el calentador de agua caliente y el sistema ProLock.
- **Conexión a tubo de cobre:** 18 pulgadas es la distancia mínima que debe existir para hacer una conexión con soldadura en un caño de cobre insertado en una conexión ProLock. Asegúrese de que el flujo de la soldadora no entre en contacto con la conexión.
- **Concreto y mampostería:** Los tubos y conexiones ProLock pueden ser puestos en concreto y mampostería siempre y cuando sean instalados en tubos conductos con cajas de acceso a las conexiones. Esto es para permitir que el tubo se expanda y proveer accesibilidad tanto a los tubos como a las conexiones. Las conexiones y tubo deben ser removibles para posible reemplazo. También se recomienda aislamiento para proteger de pérdida de calor y de las heladas. Las conexiones no pueden ser utilizadas bajo tierra.
- **Continuidad eléctrica:** En caso de que el sistema vaya a ser usado en una instalación metálica ya existente, la continuidad eléctrica debe ser reestablecida.
- **Pruebas de sistema:** Para asegurarse de que la tubería y las conexiones han sido instaladas correctamente, ya sea en un sistema nuevo o en uno extendido, es esencial probarlo y verificarlo con agua corriente. Esta prueba debe realizarse a 30 psi por 10 minutos y 150 psi por 10 minutos. Esta prueba combinada con otras debiera revelar problemas en la instalación y es considerada un buen ejercicio de la plomería. En todo caso, la prueba del sistema no debe ser considerado como substituto para instalación correcta. (ver además "haciendo una buena conexión").
- **Desinfección de sistemas de agua fría y caliente:** ProLock puede ser desinfectado después de su instalación o como parte de un programa de mantenimiento de rutina. El procedimiento de desinfección debe realizarse de acuerdo a las regulaciones existentes. Solo pueden ser usados líquidos desinfectantes específicamente recomendados como aptos para el contacto de los sistemas de plomería de plástico y en los lugares que sea necesario, especialistas en desinfección pueden ser contratados. Las soluciones desinfectantes solo deben entrar en contacto con la superficie interior (mojada) del sistema. Si cualquier parte normal externa (seca) de la conexión ProLock entra en contacto con el líquido desinfectante la conexión completa debe ser reemplazada inmediatamente. El líquido desinfectante debe ser purgado en todos los puntos de salida con agua dulce limpia al finalizar el proceso de desinfección. El líquido desinfectante no puede quedar en el sistema.
- **Drenaje del sistema:** Como práctica habitual para cualquier instalación de plomería, se recomienda el drenaje del sistema ProLock antes de usar por primera vez de manera que se elimine todo residuo químico/contaminante en la instalación.
- **Plagas de insectos:** Los productos ProLock necesitarán protección especial en áreas infestadas con plagas de insectos.
- **Profundidad de tubos interiores:**

	3/8" CTS	1/2" CTS	3/4" CTS	1" CTS
PSEI	N/A	1 3/8"	1 5/8"	1 5/8"
MWI	1 1/16"	1 1/8"	1 1/2"	1 1/2"

- **Cargas Laterales:** Los conectores no deben ser sujetos a sobrecarga lateral y no deben ser usados como tabiques de soporte. La tubería debe estar adecuadamente sujeta para prevenir una carga lateral excesiva.
- **Par Máximo de Valores para Roscas:** en Ft Lbs

	1/2" NPT	3/4" NPT	1" NPT
Plastico	2	3	3
Metal	3	4	4

Se recomienda que todas las instalaciones sean chequeadas/verificadas previo a su uso para determinar que el sellado se ha hecho.

John Guest USA, Inc. no se responsabiliza por los errores de imprenta o tipográficos.

TERMS AND CONDITIONS

The products described in this document are hereby offered for sale to be established by John Guest (USA) Inc., its subsidiaries and its authorized distributors. This offer and its acceptance by any customer (the "Buyer") shall be governed by all of the following Terms and Conditions. Buyer's order for any item described in this document, when communicated to John Guest (USA) Inc., its subsidiaries or an authorized distributor (the "Seller") verbally or in writing, shall constitute acceptance of this offer.

1. Terms and Conditions of Sale. All descriptions, quotations, proposals, offers, acknowledgments, acceptances and sales of the Seller's products are subject to and shall be governed exclusively by the terms and conditions stated herein (the "Agreement"). The Buyer's acceptance of any offer to sell is limited to the terms and conditions in the Agreement. Any terms or conditions in addition to, or inconsistent with those stated in the Agreement, proposed by the Buyer in any acceptance of an offer by the Seller, are hereby objected to. No such additional, different or inconsistent terms and conditions shall become part of the agreement between the Buyer and the Seller unless expressly accepted in writing by the Seller. The Seller's acceptance of any offer to purchase by the Buyer is expressly conditioned upon the Buyer's assent to all the terms and conditions in this Agreement, irrespective of any terms in addition to, or inconsistent with those contained in the Buyer's offer. Acceptance of the Seller's products shall in all events constitute such assent.

2. Documents. Unless provided otherwise in the Agreement, all catalog descriptions, illustrations, drawings and literature or independently submitted estimates of performance, weights and measurements or other specifications provided by the Seller are mere approximations and the Seller reserves the right to alter or amend the same at any time. The Seller reserves the right to correct clerical or technical errors in the contract documents. The Buyer shall furnish with his order all necessary specifications and information. The Seller takes no responsibility for goods manufactured, PRECIO'd or delivered not in accordance with the order or the specifications unless the Buyer's order and specifications are clear and correct.

3. PRECIOS. Unless otherwise provided, all PRECIOS contained in our quotations and written acceptances are ex works and do not include the cost of packing. All orders are accepted on the condition that all such PRECIOS are subject to revision by the Seller at any time before the goods are dispatched to take account of any PRECIO change. In the event that the Buyer does not place the entire order quoted by the Seller for the Buyer, the Seller reserves the right to revise its PRECIOS. The Seller also reserves the right to revise its PRECIOS if the Buyer modifies the specification or quantity of the goods, or the delivery requirements after the order has been accepted by the Seller.

4. Advice. All advice given in connection with the Seller's goods is provided without charge to the Buyer. Any advice and assistance given by the Seller to the Buyer is given at the Buyer's risk and the Seller shall not be liable for any loss, damage or claim arising therefrom.

5. Payment. (a) Unless otherwise provided in the Agreement, or explicitly agreed upon in writing by the Seller, payment is due in full 30 days from date of shipment of the items purchased herein under. (b) In the case of an installment contract, deliveries or parts, payment for each installment delivery or part shall be made under sub-clause (a) as if the same constituted a separate agreement. (c) Amounts not timely paid shall bear interest at the rate of 2-1/2% above the Seller's bank's prime rate from time to time in force. (d) A bank fee shall apply to all payments received via wire transfer. (e) Payments made with a credit card shall incur a 2% bank fee. (f) In the event that the Buyer fails within one calendar month of the date for payment to effect any payment which may be due under the Agreement or any agreement with the Seller, or if the Buyer commits any breach of the Agreement, or if the Buyer becomes insolvent or commits any act of bankruptcy or contemplation of liquidation, the Seller will be entitled, without prejudice to the Seller's other rights, to terminate the Agreement or any unfulfilled part thereof, or at the Seller's option to make partial deliveries.

6. Modifications and Cancellations. This Agreement is not subject to oral modification or cancellation. A Buyer's request for modification or cancellation will not be incorporated into the Agreement unless the request is accepted by the Seller in a writing that amends the Agreement. Acceptance of any such requested modification or cancellation shall be at the Seller's discretion and shall be upon such terms and conditions as the Seller may require.

7. Handling Charge. Goods supplied in accordance with the Buyer's order may later be returned to the Seller at the Seller's discretion provided the return is pre-authorized, in writing and the merchandise is unused, in original packages, unaltered, clean and no older than 60 days from the date of shipment by the Seller. The Buyer shall pay to the Seller a handling charge of 25% of the purchase PRECIO of the returned goods. A copy of the original invoice for the merchandise must accompany all returns.

8. Delivery. (a) Any delivery dates quoted are approximate only and the Seller shall have no liability for any delays in delivery. (b) Unless provided otherwise, delivery of the goods shall be made when the Seller has notified the Buyer that the goods are ready for dispatch. Regardless of the method of delivery, delivery shall be made F.O.B. Seller's plant, where the risk of loss shall thereupon pass to the Buyer upon the Seller's delivery to a carrier. Notwithstanding that the Seller's PRECIOS are ex-works, the Seller is prepared by special contract to procure carriage or freight and insurance on behalf of the Buyer and at Buyer's cost in which event the Seller shall be under no liability for damage in transit or loss or damage to the goods beyond the point at which the Seller contracts to deliver the same. (c) Seller will not make drop shipments.

9. Inspection and Rejection. (a) The following provisions shall apply in relation to all deliveries of goods: the Seller shall not be held liable for any claims of damage in transit, shortage of delivery or loss of goods, unless in the case of shortage of delivery, a separate notice in writing is given to the carrier concerned and to the Seller within three (3) days of the receipt of the goods, followed by a complete claim in writing within five (5) days of receipt of the goods and in the case of loss of goods, a separate notice in writing is given to the carrier concerned and to the Seller and a complete claim in writing made within thirty (30) days of the date of consignment. The Buyer must inspect the goods on arrival from the carrier, however, where goods are accepted from the carrier concerned without being inspected, the delivery book of the carrier concerned must be signed "not examined". The Seller shall have the right to inspect the goods at the Buyer's premises in respect to any such claims made by the Buyer and the Buyer shall retain such goods until the Seller has inspected such goods or until the Seller has notified the Buyer that the Seller does not wish to inspect such goods. Any breach of these conditions in this provision shall serve as a waiver to any claim brought by the buyer. (b) Without prejudice to the Seller's other rights, should the Buyer fail for any reason to send the Seller forwarding instructions within ninety (90) days after the date of the Seller's notification that the goods are ready for dispatch or to accept delivery of the goods, the Seller shall be entitled at the Buyer's risk and expense to store the goods and/or to procure or effect storage of the goods elsewhere. Goods so stored shall be paid for as if they had been dispatched and/or accepted.

10. Special Tooling. Where it is necessary for the Seller to manufacture or to purchase special tooling, including without limitation tools, dies, jigs, mandrills, fixtures, molds, and patterns in order to execute a contract, the Buyer will be charged with a proportion of the cost of such special tools. Such special tooling shall be and remain the Seller's property notwithstanding payment of any charges made by the Buyer. In no event will the Buyer acquire any interest in apparatus belonging to the Seller which is utilized in the manufacture of the items sold hereunder, even if such apparatus has been specially converted or adopted for such manufacture and notwithstanding any charges paid by the Buyer therefore. Unless otherwise agreed, the Seller shall have the right to alter, discard or otherwise dispose of any special tooling or other property in its sole discretion at any time.

11. Test and Performance. (a) The Seller's goods are, where practicable, submitted to the Seller's standard test before delivery. If special tests are required, these shall be made at the Seller's premises unless otherwise agreed, and will be subject to an extra charge. (b) The Seller accepts no liability for failure to attain any performance figures quoted by the Seller unless the Seller specifically has guaranteed them with an agreed sum as liquidation damages and the Buyer has suffered actual loss by reason of the failure to attain the figures quoted. (c) Any particulars of weights and measurements, power and consumption, power output or performance relating to the goods and like matters furnished by the Seller to the Buyer in the Seller's catalogs, literature or otherwise, are approximate and are intended only to present a general idea of the goods to be supplied and unless previously agreed specifically in writing shall not form part of the Agreement.

12. Buyer's Property. Any designs, tools, patterns, materials, drawings, confidential information or equipment furnished to the Seller by the Buyer, or any other items which become the Buyer's property, may be considered obsolete and may be destroyed by the Seller after two (2) consecutive years have elapsed without the Buyer placing an order for the items which are manufactured using such property. The Seller shall not be responsible for any loss or damage to such property while it is in the Seller's possession or control.

13. Taxes. Unless otherwise indicated, all PRECIOS and charges are exclusive of excise, sales, use, property, occupational or like taxes which may be imposed by any taxing authority upon the manufacture, sale or delivery of the items sold hereunder. If any such taxes must be paid by the Seller, or if the Seller is liable for the collection of such tax, the amount thereof shall be in addition to the amounts for the item sold. The Buyer agrees to pay all such taxes or to reimburse the Seller therefore upon receipt of its invoice. If the Buyer claims exemption from any sales, use or other tax imposed by any taxing authority, the Buyer shall promptly indemnify and hold the Seller harmless from and against any such tax, as well as any interest or penalties thereon which may be assessed if the items are held to be taxable.

14. Warranty. (a) The Seller warrants that the items sold hereunder shall be free from defects in material or workmanship at the time of shipment by the Seller. The Seller warrants that if within 12 months of delivery of the goods to the Buyer the Buyer returns immediately to the Seller's premises any of the said goods which the Buyer believes to be defective, carrier paid, properly packed and clearly marked with the Buyer's full name and address and any other information such as serial numbers which may be necessary to enable the goods to be identified, together with a complete description of the respects in which it is alleged that the goods are defective, they will be repaired or new goods will be supplied in exchange and the goods so repaired or such new goods will be delivered to the Buyer free of charge at the Seller's premises provided that the foregoing warranty shall only be applicable if upon demand by the Seller, the Buyer proves to the Seller's satisfaction: (i) that the defect was due solely to defective workmanship; (ii) that no alterations or repairs have been made to the goods except with the Seller's written consent; (iii) that the defect was not caused by any act of the Buyer or its agents; and (iv) that the defect was not caused by any matter beyond the reasonable control of the Seller, including, without limitation, accident or normal wear and tear. (b) For John Guest PSEI, MWI Series Plumbing products and ProLock™ PEX Pipe only, the warranty period contained in sub-paragraph (a) may be extended to 300 months (25 years) from date of delivery of the goods to the Buyer provided that, in addition to all other requirements, Seller's products are: (i) used in domestic plumbing applications; (ii) installed by a Licensed Contractor, Plumber or qualified equipment installation professional; and (iii) installed and operated in accordance with published John Guest technical specifications. (c) All costs and expenses, including freight charges, customs duties, and insurance incurred in returning the goods to the Seller's premises in accordance with this provision shall be paid by the Buyer. The benefit of this warranty shall not be assignable by the Buyer. (d) The warranty contained in sub-paragraphs (a) and (b) above does not extend to any goods not manufactured by the Seller even though supplied by the Seller nor does it extend to any second-hand or reconditioned goods nor does it extend to components manufactured by the Seller but installed, attached or welded by the Buyer or his customer on equipment not manufactured by the Seller. Goods not manufactured by the Seller carry only the warranty (if any) of their makers and the Buyer is entitled to the benefit thereof only so far as the Seller has the power to transfer it. (e) This warranty comprises the sole and entire warranty pertaining to items provided hereunder; the Seller makes no other warranty, guarantee, or representation of any kind whatsoever. All other warranties, including but not limited to, merchantability and fitness for purpose, whether expressed or implied, or arising by operation of law, trade usage, or course of dealing are hereby disclaimed. (f) Notwithstanding the foregoing, there are no warranties whatsoever on items built or acquired wholly or partially to the Buyer's designs or specifications.

15. Limited Remedy. The Seller's liability arising from or in any way connected with the items sold or this Agreement shall be limited exclusively to repair or replacement of the items sold. In no event shall the Seller be liable to the Buyer or any 3rd party for any incidental, consequential or special damages of any kind or nature whatsoever, including but not limited to lost profits arising from or in any way connected with this agreement or items sold hereunder, whether alleged to arise from breach of contract, express or implied warranty, or in tort, including without limitation, negligence, failure to warn or strict liability.

16. Indemnity for Infringement of Intellectual Property Rights. (a) The Buyer shall defend and indemnify the Seller against all actions, claims, demands, penalties and costs by 3rd parties in tort, or for infringement, or alleged infringement, of patents, trademarks, copyrights, trade dress, trade secret or other rights of any 3rd party resulting from the goods manufactured in accordance with the Buyer's specifications or based on any information provided by the Buyer. The Buyer will defend any action against the Seller for title, patent, trademark, copyright infringement, or other claimed by a 3rd party at the Buyer's sole cost and expense. (b) The Seller shall have no liability for infringement of any patents, trademarks, copyrights, trade dress, trade secrets or similar rights except as provided in this provision. The Seller will defend and indemnify the Buyer against allegations of infringement of US patents, US trademarks, copyrights, trade dress and trade secrets ("Intellectual Property Rights"). The Seller will defend at its expense and will pay the cost of any settlement or damages awarded in an action brought against the Buyer based on an allegation that an item sold pursuant to this contract infringes the Intellectual Property Rights of a 3rd party. The Seller's obligation to defend and indemnify the Buyer is contingent on the Buyer notifying the Seller within 10 days after sole control over the defense of any allegations or actions, including all negotiations for settlement or compromise. If an item sold hereunder is subject to a claim that it infringes the Intellectual Property Rights of a 3rd party, the Seller may, at its sole expense and option, procure for the Buyer the right to continue using said item, replace or modify said item so as to make it non-infringing, or offer to accept return of said item and return the purchase PRECIO less a reasonable allowance for depreciation. Notwithstanding the foregoing, the Seller shall have no liability for claims of infringement based on information provided by Buyer, or directed to items delivered hereunder for which the designs are specified in combination or use in a system of any item sold hereunder. The foregoing in this provision shall constitute the Seller's sole and exclusive liability and the Buyer's sole and exclusive remedy for infringement of Intellectual Property Rights.

17. Lien. In addition to any right of lien to which the Seller may by law be entitled, the Seller shall have a general lien on all goods of the Buyer in the Seller's possession (although such goods or some of them may have been paid for) for the unpaid PRECIO of any other goods sold and delivered to the Buyer by the Seller under the same or other contracts.

18. Waiver. The Seller's rights shall not be affected or restricted by any indulgence or forbearance granted to the Buyer. No waiver by the Seller of any breach shall operate as a waiver of any later breach.

19. Force Majeure. The Seller shall be excused from performing any of its obligations under this Agreement which are prevented or delayed by any occurrence not within the reasonable control of the Seller, including but not limited to, accidents, acts of God, destruction or damage to the goods or the Seller's manufacturing plant, delays or failures in delivery of carriers or suppliers, shortages of materials, strikes or other labor matters, floods, earthquakes, fire, riots, explosions, or any regulations, rules, ordinances or orders of any governmental authority, federal, state or local, whether such cause exists at the date of the order or not.

20. Buyer's Representation of Solvency. The Buyer hereby represents that as of the signing of this Agreement it was not insolvent within the meaning of the Uniform Commercial Code or the Bankruptcy Laws of the United States.

21. Assignment and Delegation. The rights and obligations of the parties under this Agreement may not be assigned or delegated, except on the express written consent of the other party to the assignment or delegation.

22. Integration. The rights and obligations of the parties and the terms and conditions set forth herein, together with any amendments, modifications and any different terms and conditions expressly accepted by the Seller in writing, shall constitute a complete and exclusive statement of the terms of this Agreement. This Agreement supersedes not only all prior agreements, but also oral agreements made contemporaneously with the execution of this Agreement. All such materials may not be used to supplement, explain, or contradict the terms of this Agreement.

23. Severability. If any of these conditions or any part thereof purports to exclude or restrict or limit any liability and such exclusion or restriction or limitation is prohibited or rendered void or unenforceable by any legislation to which it is subject, or is itself prohibited or rendered void or unenforceable by any legislation to which it is subject, then the exclusion restriction or limitation on the condition or part thereof in question shall be so prohibited or rendered void or unenforceable and the validity or enforceability of any other part of these provisions shall not thereby be affected.

24. Governing Law/Limitation on Actions. The terms, conditions, rights, and obligations under this Agreement shall be construed under the laws of the State of New York, without regard to principles of conflicts of laws. No actions arising out of the sale of the items sold hereunder or this Agreement may be brought by the Buyer more than two (2) years after such cause of action accrues.



John Guest USA, Inc.

DIRECCIÓN

180 Passaic Avenue,
Fairfield, NJ, 07004

WEB

JGProlock.com

CORREO ELECTRÓNICO

info@johnguest.com

TEL

800-945-4872
973-808-5600

FAX

973-808-5036

CORREO ELECTRÓNICO PARA PEDIDOS/ORDENES

jgusa.orders@johnguest.com

John Guest USA, un proveedor de productos para sistemas de fluidos líder en el mundo, ubicado en el norte de Nueva Jersey, es parte de una organización profesional y progresista con diversas sedes en el mundo. Durante más de 50 años, la organización John Guest ha forjado su reputación al ofrecer productos de alta calidad y altos niveles de servicio de atención al cliente.

A través de un compromiso firme con el crecimiento y la innovación, John Guest USA continuará sirviendo a su comunidad y a sus clientes durante muchos años más.

John Guest USA, Inc. distribuye sus productos en América del Norte, América Central, América del Sur, el Caribe y las Islas Vírgenes de Estados Unidos.

John Guest USA, Inc. no se responsabiliza por los errores de imprenta o tipográficos.

CONEXIONES A NIVEL MUNDIAL

John Guest Group tiene una reputación consolidada desde hace tiempo como líder mundial en la fabricación de conectores de empuje, tubos y otros productos para el control de fluidos. Una reputación forjada por la producción permanente de productos de alta calidad con un compromiso continuo de valorar la ingeniería y el desarrollo de productos.

FABRICACIÓN DE CALIDAD

Tanto el diseño como la fabricación se llevan a cabo en las modernas instalaciones de John Guest construidas especialmente para dichas tareas en el Reino Unido.

Llevar un control de la totalidad del proceso, desde el diseño inicial de la herramienta y su fabricación hasta el ensamblaje final y la prueba, garantiza que solo se fabriquen productos de la más alta calidad. Este compromiso con la calidad le ha proporcionado a la empresa prestigiosos premios de muchas de las organizaciones de evaluación y acreditación líderes en el mundo.

John Guest es un proveedor preferido por muchas empresas internacionales.



JG John Guest® y **JG ProLock®** SON MARCAS

REGISTRADAS DE JOHN GUEST INTERNATIONAL LIMITED COPYRIGHT © 2018



John Guest

Horton Road, West Drayton,
Middlesex, UB7 8JL, England
T: **(44) (0) (1895) 449233**
F: **(44) (0) (1895) 420321**



John Guest s.r.l.

Via Vincenzo Lancia 13,
10038 Casabianca -
Verolengo (Torino), Italy
T: **(39) (011) 957 5880**
F: **(39) (011) 957 6144**



John Guest France S.A.

143-147 Avenue Charles
Floquet, Parc Gustave Eiffel,
F-93593 Le Blanc-Mesnil,
Cedex, France
T: **(33) (0) 1 48 65 52 29**
F: **(33) (0) 1 48 65 43 40**



John Guest s.l.

C/ de La Electronica No. 7,
Poligono Industrial La Ferreria,
Montcada I Reixac, 08110
Barcelona, Spain
T: **(34) (93) 575 0027**
F: **(34) (93) 575 0178**



John Guest GmbH

Ludwig-Erhard-Allee 30,
D-33719 Bielefeld, Germany
T: **(49) (521) 972 560**
F: **(49) (521) 972 5680**



John Guest Korea Limited

Unit 552-27 Kajwa Dong,
Seo Ku, Incheon City,
404-812 Korea
T: **(82) (32) 584 3370**
F: **(82) (32) 584 3372**



John Guest Czech s.r.o.

Vrbenská 2290,
CZ-37001 České Budějovice,
Czech Republic
T: **(420) (387) 002 040**
F: **(420) (387) 002 048**



John Guest Pacific Limited

P.O. Box 19553, 606 Rosebank
Road, Avondale, Auckland,
New Zealand
T: **(64) (9) 828 1353**
F: **(64) (9) 828 5927**



John Guest Polska Sp. z o.o.

Ul. Starołęcka 7,
PL 61-361 Poznań, Poland
T: **(48) (61) 87 80 408**
F: **(48) (61) 87 80 285**



John Guest Pacific Ltd.

Unit 6, 33 Nyrang Street;
Lidcombe, Sydney
N.S.W. 2141, Australia
T: **(61) (2) 9737 9088**
F: **(61) (2) 9737 9122**